

FITTING INSTRUCTIONS

PRECAUTIONS:

Before carrying out any work on the machine or its exhaust, ensure that the temperature of the power unit and exhaust will cause no harm either to the operator or to parts which are not heat resistant (such as fairing, hoses, sleeves etc)

FITTING;

1. Remove the OE silencer
2. Fit the LeoVince silencer, aligning the header pipe with the exhaust flange on the power unit, and remembering to fit the sealing gasket when available. Partially tighten the two nuts on the mounting studs to allow a degree of realignment. This is made possible by the clearance between the flange and the mounting studs on the power unit.
3. Fit the brackets supplied, following the indications on the drawing enclosed, where you will see clearly described the correct relationship between the various spacers, washers (when required), and fasteners
4. Tighten up all the fasteners, starting with those on the mounting flange at the power unit.
5. Start the motor, wait a few minutes for it to reach operating temperature, and check that there are no gas leaks.

NB: after approximately 100 Km, check all the fasteners.

MAINTENANCE:

From time to time, check all the brackets and fasteners, which could be affected by use (sound-deadening material, seals and other rubber parts) and replace them periodically. The silencer may be cleaned using gasoline, diesel oil or alcohol. Absolutely avoid the use of any kind of solvent.

IT IS FORBIDDEN to make any modifications to silencers. Whatever form this may take, SITO GRUPPO INDUSTRIALE declines any responsibility for defects, problems, or malfunction arising from the use of any product which has been modified or tampered with.

TECHNICAL DRAWING

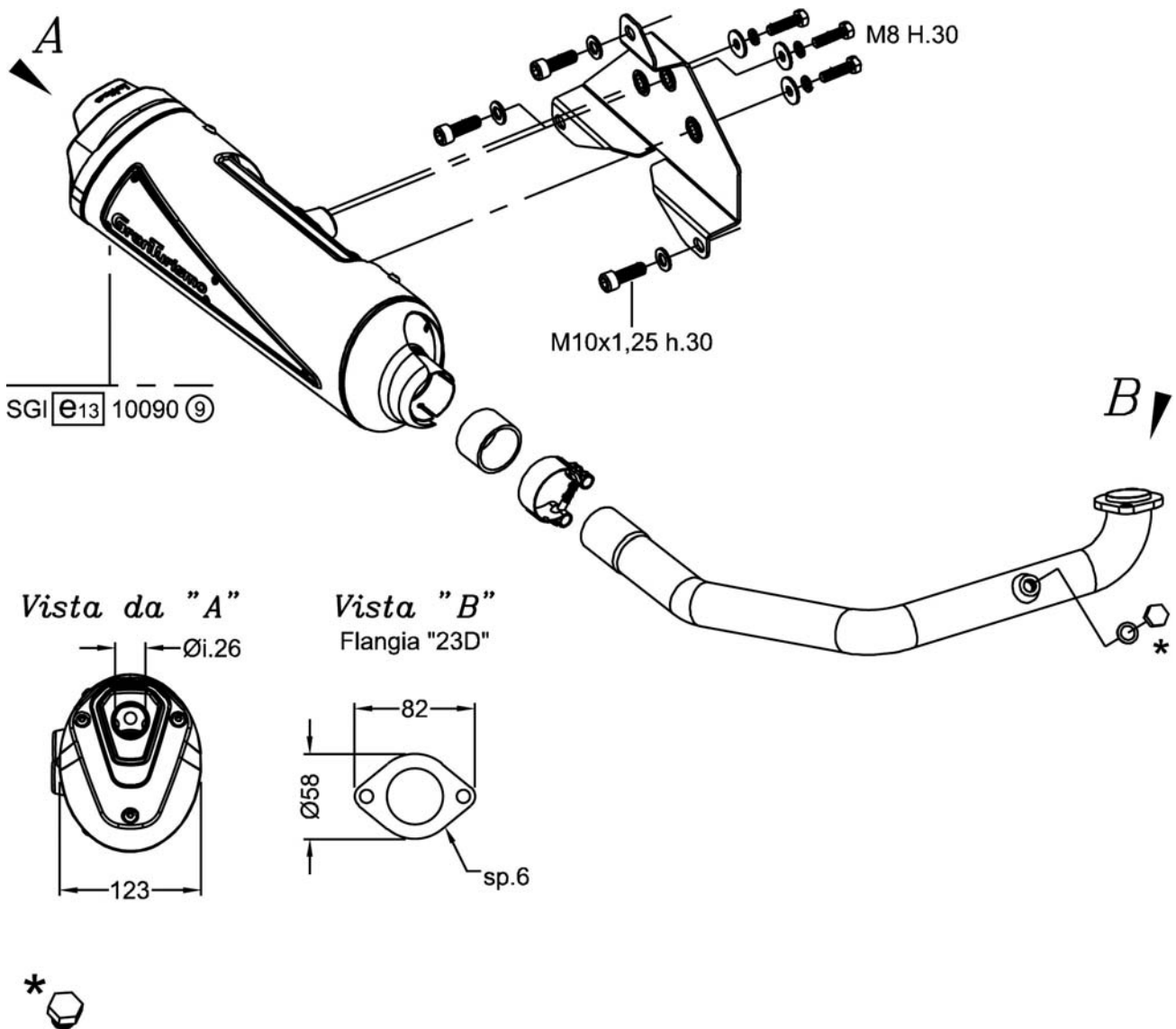

I) Componenti forniti in confezione e da utilizzare solo sulle motociclette non dotate di sonda Lambda:

.Guarnizione + Tappo M12x1,25 h.9

GB) By-packed components to be used only on motorcycles not provided with Lambda probe: .Seal + Plug M12x1,25 h.9

F) Pièces fournies et à utiliser seulement sur les motocycles qui ne sont pas équipés de sonde Lambda:

.Garniture + Bouchon M12x1,25 h.9

D) Mitgelieferte Bauteile, die nur für Motorräder ohne Lambda-Sonde einzusetzen sind: .Dichtung + Stopfen M12x1,25 h.9

E) Componentes suministrados en confección y que hay que utilizar sólo en las motocicletas no equipadas de sonda Lambda:

.Guarnición + Tapón M12x1,25 h.9