

Thank you for purchasing **KOSO DB-01 digital LCD meter**, before operating the unit, please read the instruction thoroughly and retain it for the future reference.

Notice

1. The meter is apply for **DC 12V**.
2. For installation, please follow the steps described in manual. Any damage caused by wrong installation shall be imputed to the users.
3. To avoid the short circuit, please don't pull the wire when installing. Don't break or modify the wire terminal.
4. Do not disassemble or change any parts excluding the manual description.
5. The interior examination or maintenance should be executed by our professionals.

MARK MEANING:

NOTE You could get the installation details from the Information behind the mark.

△ Some processes must be followed to avoid the affection caused by wrong installation.

△ WARNING! Some processes must be followed to avoid damages to yourself or the public.

△ CAUTION! Some processes must be followed to avoid the damage to the vehicle.



PRESS THE BUTTON ONE TIME



PRESS THE BUTTON 3 SECONDS

1-1 Accessory

1 Meter X 1

2 Main wiring X 1

3 RPM wire set X 1

4 Passive speed sensor X 1

5 D6 X 5L mm magnet X 6

6 Mid-way connect X 8

7 M8/ S type speed sensor bracket X 1

8 M10/ S type speed sensor bracket X 1

9 Hexagon socket screw X 2

10 2.5 mm spanner X 1

11 4 mm spanner X 1

12 Meter bracket X 1 set

13 M5 X 12L screw X 2

14 M4 screw X 2

15 M4 gasket X 2

NOTE Please contact the local distributor if the items you open are not the same, with the above-listed one.

1-2 Option accessory

1 Disc magnet screw

5/16-18 X 22.1L
M5 X P0.8 X 12L
M6 X P1.0 X 12.6L
M6 X P1.0 X 19.7L
M6 X P1.0 X 24L
M8 X P1.25 X 22.5L M8 X P1.25 X 27.5L
M8 X P1.25 X 29L M10 X P1.25 X 28.3L

2 Active speed sensor

3 Digital speed signal sensor

JIS TYPE α

4 Digital speed signal sensor

JIS TYPE A

5 Digital speed signal sensor

RUNNER

6 Digital speed signal sensor

SR X-FIGHT BOOSTER

7 L type speed sensor bracket

8 Meter bracket (for handle switch)

NOTE The advantage of the active speed sensor is as following, 1. You don't need to install the magnet in the opposite position of the speed sensor. 2. You could set up the sensor signal input up to 60 points, and the speed displayed will be more accurate. Please note that the speed sensor attached in the kit is passive speed sensor, and the maximum speed signal it could read is 6 points.

NOTE Some of the option accessories may not sell. For the details, please contact the local distributor.

2-1 Wiring installation instructions

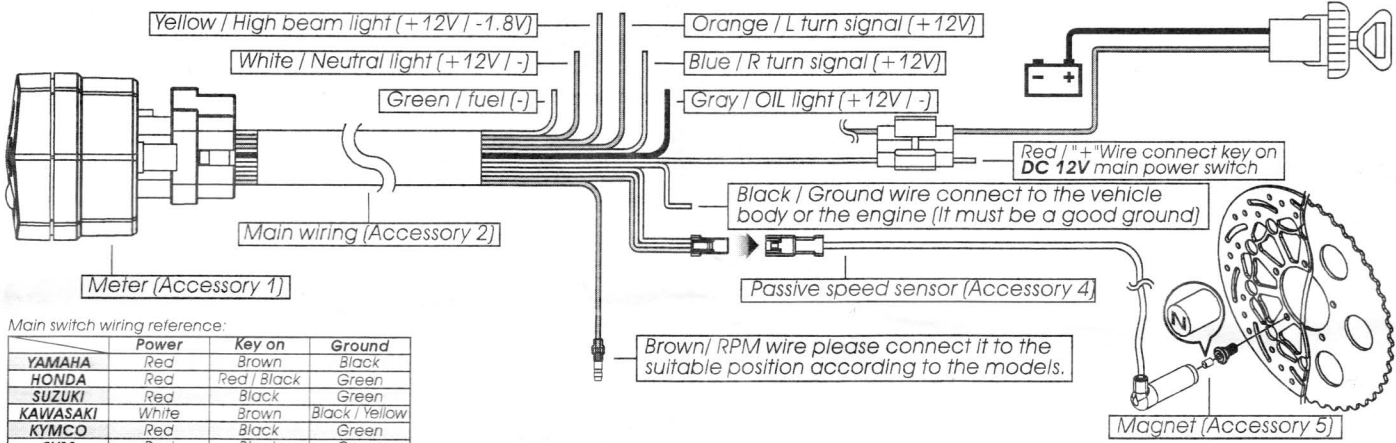

Main switch wiring reference:

	Power	Key on	Ground
YAMAHA	Red	Brown	Black
HONDA	Red	Red / Black	Green
SUZUKI	Red	Black	Green
KAWASAKI	White	Brown	Black / Yellow
KYMCO	Red	Black	Green
SYM	Red	Black	Green
PGO	Red / White	Orange	Black

NOTE The color listed above may differ depending on the model.

RPM wiring reference:

		BUELL	
YAMAHA	Yellow / Black		Pink
HONDA	Yellow / Green	CAGIVA	Gray / Green
SUZUKI	Yellow / Blue	DUCATI	Gray / Green
KAWASAKI	Light Blue	H-D	Pink
APRILIA	Gray / Violet	MV	Gray / Yellow
BMW	Black	TRIUMPH	Red
BENNELLI	Gray / Violet		

NOTE The color listed above may differ depending on the model.

Fuel indicator wiring reference:

		KYMCO	Yellow / White
YAMAHA	Green		
HONDA	Yellow / White	SYM	Yellow / White
SUZUKI	Yellow / White	PGO	Gray
KAWASAKI	Black / L Green		

⚠ The fuel sensor is electronic type, please don't parallel connection with the original- otherwise the fuel gauge won't display.

The wrong installation of the fuel wiring may cause the meter break.

⚠ The RPM wire installation -

A. Please connect the RPM wire to connect to the ignition coil positive pole.

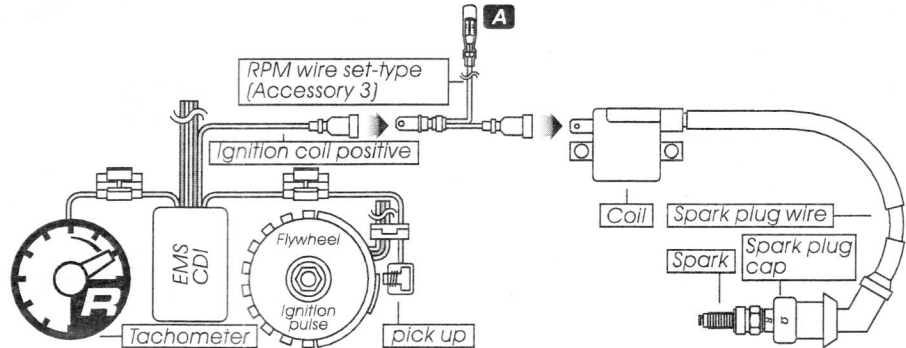

2-2 Installation instructions

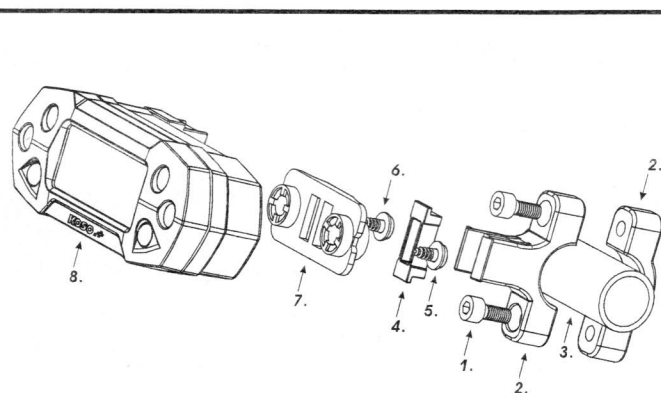

When installing, please follow the process.

1. M5 X 12L screw X 2
2. Meter bracket for handle bar
3. Fix the bracket on handle bar (7/8 inch)
4. Meter bracket clip X 1
5. M4 screw X 2
6. M4 gasket X 2
7. Meter fixed board
8. Fix the meter on the board (7) with the gasket (6) screw (5)
9. Fix the meter and the bracket together
10. Pull the meter bracket clip upward to fix the bracket.

NOTE Please adjust the meter to the best visible angle before tightening the screw

Special instruction for meter fix board.



A. Push meter bracket clip up to lock meter fix board (with meter) on bracket



B. Push meter bracket clip down to release meter fix board (with meter) on bracket

MOTO / SCOOTER S type speed sensor bracket instruction

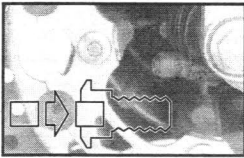

Put the magnet into the brake disc screw hole.

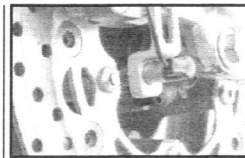

Install the speed sensor on the bracket.

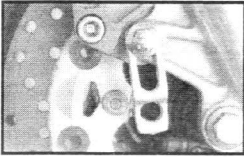

Install the s type sensor bracket.



Adjust the distance between sensor and magnet. We suggest you to make sure the distance is under **8 mm** for catching good speed signal.

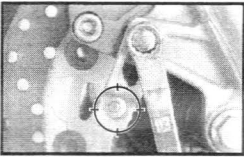

Adjust the sensor bracket position to make sure that the sensor could face the magnet to prevent bad speed signal or no signal!

MOTO / SCOOTER L type speed sensor bracket instruction

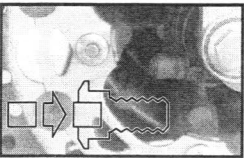

Put the magnet into the brake disc screw hole.

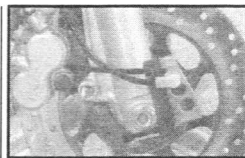

Install the speed sensor on the bracket.

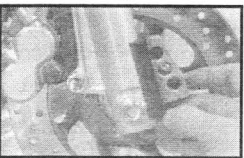

Please install the L bracket and the anti-slip rubber on the front fork and adjust it to the proper height and angle.

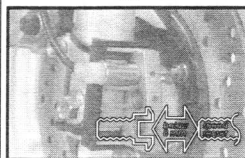

Adjust the distance between sensor and magnet. We suggest you to make sure the distance is under **8 mm** for catching good speed signal.

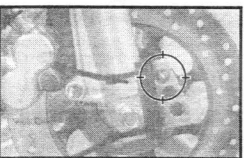

Please use the cable tie to fix the bracket on the front fork. Please make sure the disc screw could pass the hole on the bracket for you to install the sensor into the same hole for catching the speed signal.

ATV S type speed sensor bracket instruction

1. Put the magnet into the brake disc screw hole.
2. Install the s type sensor bracket. Adjust the sensor bracket position to make sure that the sensor could face the magnet to prevent bad speed signal or no signal!
3. Install the speed sensor on the bracket. Adjust the distance between sensor and magnet. We suggest you to make sure the distance is under **8 mm** for catching good speed signal.

NOTE About the setting, please refer to **4-2** tire circumference and sensor point setting.

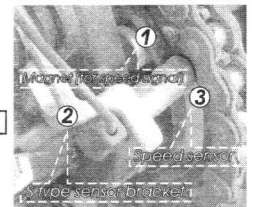

P.S.



The more magnet sensor points are, the less the display interval is. when installing the magnet, please put the magnet with **N**-mark side face the outside and put them averagely to avoid wrong signal.

EX. 1: If your disk has 3 screws, you could install 1 or 3 magnets to catch the speed.

EX. 2: If your disk has 4 screws, you could install 1、2 or 4 magnets to catch the speed.

EX. 3: If your disk has 5 screws, you could install 1 or 5 magnets to catch the speed.

EX. 4: If your disk has 6 screws, you could install 1、2、3 or 6 magnets to catch the speed.

After finishing the magnet installation and sensor point setting, please move your tire to test the speedometer work or not.

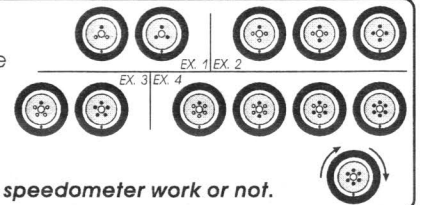

3-1 Basic function instruction

Tachometer

- Display range: 0~15,000 RPM.
- Display unit: 500 RPM (0~10,000 RPM)
- Display unit: 250 RPM (10,000~15,000 RPM)

Fuel meter

- Display range: 5 levels.
- Display unit: Each level represents 20 %.

Insufficient fuel warning

- Display range: The fuel symbol will flash when the fuel is less than 20 %

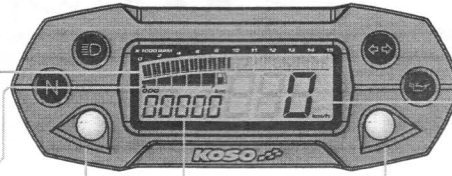

Adjust button

Select button

Odo meter

- Display range: 0~99999 km (mile), reset automatically after 99999 km (mile).
- Display unit: 1 km (mile).

Trip meter

- Display range: 0~999.9 km (mile), reset automatically after 999.9 km (mile).
- Display unit: 0.1 km (mile).

Indicator lights

- Neutral light (Green) N
- High beam light (Blue)
- Direction light (Green)
- Oil light (Red)

Speedometer

- Display range: 0~360 km/h (0~223 MPH).
- Display unit: km/h or MPH.

Adjust button

- In the main screen, to press the **Adjust button** to switch between odometer and trip meter.
- In the trip meter screen, to press down the **Adjust button** for 3 seconds to reset the trip meter.

3-2 Function, setting instruction

● Speedometer	Display range: 0~360 km/h (0~223 MPH) Display unit: km/h & MPH for alternative	○ Display internal	<0.5 second
○ Display internal	<0.5 second	○ Stroke / piston setting	2 Stroke: 1, 2, 3, 4 pistons 4 Stroke: 1, 2, 3, 4, 5, 6, 8, 10, 12 pistons
○ Odometer	Display range: 0~99999 km (mile), reset automatically after 99999 km (mile). Display unit: 1 km (mile)	● Fuel meter	Display range: 5 levels Display unit: Each level represents 20 % Setting range: 100 Ω, 510 Ω, no display
○ Trip meter A/B	Display range: 0~999.9 km (mile), reset automatically after 999.9 km (mile) Display unit: 0.1 km (mile)	Insufficient fuel warning	The fuel symbol will flash when the fuel is less than 20 %
○ Tire circumference	Setting range: 300~2,500 mm Setting unit: 1 mm · Sensitive point: 1~60	● Effective voltage	DC12V
● Tachometer	Display range: 0~15,000 RPM Display unit: 500 RPM (0~10,000 RPM) Display unit: 250 RPM (10,000~15,000 RPM)	● Effective temperature range	-10~+60°C
		● Meter standard	JIS D 0203 S2
		● Meter size	119.8 X 44 X 49.5 mm
		● Meter weight	Around 90 g
		● Indicator light color	Neutral-green, High beam-blue, Repeater-green, Oil-red

NOTE Design and specification are subject to change without notice!

NOTE If you enter the setting screen for 30 seconds and don't press the button, it will back to the main screen automatically.

4-1 Speed unit setting



In main screen, press down the **Select & Adjust X 3 seconds** to enter the speed unit setting.



Press the **Select button** to continue the function setting.

NOTE When you leave this screen, the setting is finished.

If you just want to make this function setting, you could hold down the **Select button for 3 seconds** to back to the main screen.



Press the **Adjust button** to choose the speed unit.

EX. Now the setting is km/h.

Now the speed unit is flashing!

NOTE You could choose km/h or MPH in the speed unit setting screen.

The odometer & trip meter will change together with the speed unit.

4-2 Tire circumference and sensor point setting



In main screen, press down the **Select & Adjust X 3 seconds** to enter the speed unit setting.



EX. The tire circumference is 1,300 mm. Press the **Select button** to move to the digit you want to set.

EX. Now the original setting is 1,000 mm.

Now the 1 is flashing!

NOTE The tire circumference setting range: 300~2,500 mm, and the digit you set is from left to right in order.

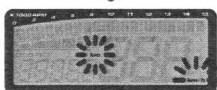

Press the **Select button** to enter the Tire circumference setting

CAUTION!

● Please measure the tire circumference (the tire you will install the sensor on) and make sure the number of magnet sensor point (You could install the magnet into the disc screw or the sprocket screw.)

● The speed displayed on the meter will be affected by the setting, please make sure the setting number is correct before you make the setting.



PS. You could define the valve as the starting point and the terminal point to measure the wheel circumference with a measuring tape.

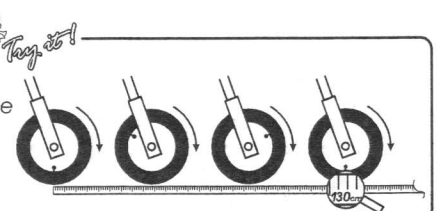

(Next page)

wh018ba000_C



Press the **Adjust** button to change the setting.

▲ Now the 0 is flashing!



Press the **Select** button for three times to enter the sensor point setting.
EX. The tire circumference setting is changed from 1,000 mm to 1,300 mm.



EX. The sensor point you want to set is 6. Press the **Select** button to move to the digit you want to set.

EX. Now the original setting is 1 point.

▲ Now the 0 is flashing!

NOTE The sensor point setting range: 1-60 points. You could change the setting from left to right.

NOTE Only when you use the active speed sensor, then you could make the sensor point setting over 6 points.



Press the **Adjust** button to choose the setting number.

▲ Now the sensor point setting number is flashing!



Press the **Select** button to continue the function setting.
EX. the sensor point setting is changed from 1 to 6.

NOTE When you leave this screen, the setting is finished.

If you just want to make this function setting, you could hold down the **Select** button for 3 seconds to back to the main screen.

4-3 Cycle / Piston / Input signal setting



In main screen, press down the **Select** & **Adjust** X 3 seconds to enter the speed unit setting.



Press the **Select** button 7 times to enter the stroke/piston/ input signal setting screen.

▲ **CAUTION!**

- Make sure the correct cycle and pistons before setting.
- Make sure the setting is correct, or the RPM output will be incorrect.
- We define the engine with the ignition system ignites every 360 degree as 2-cycle and the engine with the ignition system ignites every 720 degree as 4-cycle.
- Most of the 4-cycle bikes with one single piston are igniting EVERY 360 degree once, so the setting should be the same as the bike with 2-cycle and one piston engine.



Press the **Adjust** button to select the stroke.
EX. Now the setting is 2C (2 Stroke) 1P (1 piston) Lo (The RPM input signal is negative)

▲ Now the stroke number is flashing!

NOTE You could set the stroke as 2 stroke or 4 stroke.



Press the **Select** button to enter the piston setting screen.
EX. Now the setting is changed from 2C (2 Stroke) to 4C (4 Stroke)



Press the **Adjust** button to select the piston number.

▲ Now the piston number is flashing.

NOTE 2 Cycle: 1, 2, 3, 4 pistons
4 Cycle: 1, 2, 3, 4, 5, 6, 8, 10, 12 pistons



Press the **Select** button to enter the RPM signal input setting.

EX. The piston setting is changed from 1P (1 Piston) to 4P (4 Pistons).



Press the **Adjust** button to choose the input signal you want to set.

▲ Now the input signal setting is flashing!

NOTE The impulse setting range is between Hi (the positive impulse) & Lo (the negative impulse)

NOTE If the tachometer can't detect the signal (No RPM is displayed on the screen), you could choose another setting, and check it again.



Press the **Select** button to continue the function setting.
EX. The impulse setting is changed from Lo to Hi.

NOTE When you leave this screen, the setting is finished.

If you just want to make this function setting, you could hold down the **Select** button for 3 seconds to back to the main screen.

4-4 The fuel gauge resistance setting



In main screen, press down the **Select & Adjust X 3 seconds** to enter the speed unit setting.



Press the **Select button** 10 times to enter the fuel gauge resistance setting screen.



Press the **Adjust button** to choose the setting number. EX. Now the fuel gauge resistance setting is 100 Ω .

⚠ Now the resistance setting number is flashing!

NOTE The fuel gauge resistance setting range: 100 Ω , 510 Ω .
If you don't install the fuel wiring, the fuel gauge will not display.



Press **Select button** to back the main screen. EX. Now the fuel resistance setting is changed from 100 Ω to 510 Ω .



PS.



Usually the fuel gauge resistance is 100 Ω on YAMAHA system, and 510 Ω on HONDA system.

5 Trouble shooting

The following situation do not indicate malfunction of the meter. Please check the following before taking it in for repair.

Trouble	Check item	Trouble	Check item
The meter doesn't work when the power is on.	<ul style="list-style-type: none"> ● The power doesn't supply to the meter. <ul style="list-style-type: none"> → Please make sure the wiring is connected. The wiring and fuse are not broken. → The battery is broken or the battery is too old to supply enough power (DC 12V) to make the meter work. 	Fuel gauge does not appear or appear incorrectly.	<ul style="list-style-type: none"> ● Please check the spark plug is R type or not. If not, please replace the spark plug with the R type spark plug. ● Please check your setting. <ul style="list-style-type: none"> → Please refer to the manual 4-3. ● Please check your fuel tank. <ul style="list-style-type: none"> → Is there any fuel inside? ● Please check the wiring. <ul style="list-style-type: none"> → Do you connect the wiring correctly? ● Please check the setting. <ul style="list-style-type: none"> → Please refer to the manual 4-4.
The meter shows wrong information.	<ul style="list-style-type: none"> ● Please check the voltage of your battery, and make sure the voltage is over DC 12V. 	The odometer and trip meter is not accumulated or accumulated wrong data.	<ul style="list-style-type: none"> ● It is possible that the permanent power wire is not connected well. <ul style="list-style-type: none"> → Please check the red positive wire is connect well or not.
Speed does not appear or appear incorrectly.	<ul style="list-style-type: none"> ● Please make sure the speed sensor is connected correctly. ● Please check the tire-size setting. <ul style="list-style-type: none"> → please refer to the manual 4-2. 		
Tachometer does not appear or appear incorrectly.	<ul style="list-style-type: none"> ● Please check the RPM sensor wiring is connected correctly. 		

※If still can't solve the problems according to the steps above, please contact with distributors or us.